

Varistor Evaluation Using the Agilent B2900A Series

Technical Overview

B2900A Series Precision Source/Measure Unit

B2901A Precision SMU, 1ch, 100fA resolution, 210V, 3A DC/10.5A pulse

B2902A Precision SMU, 2ch, 100fA resolution, 210V, 3A DC/10.5A pulse

B2911A Precision SMU, 1ch, 10fA resolution, 210V, 3A DC/10.5A pulse

B2912A Precision SMU, 2ch, 10fA resolution, 210V, 3A DC/10.5A pulse

Introduction

A varistor is a variable resistor that exhibits high resistance at low voltages and low resistance at high voltages. Varistors typically have a clamping voltage above which their resistance decreases significantly (similar to a zener diode). Due to their variable resistance, varistors are frequently used as a transient voltage suppressor (TVS) to protect electrical circuitry from excessive voltages.

The Agilent B2900A Series of Precision Source/Measure Units are compact and cost-effective benchtop Source/Measure Units (SMUs) with the capability to output and measure both voltage and current.

The B2900A Series enables you to make a wide range of current versus voltage (IV) measurements more accurately and quickly than ever before. In addition, the B2900A Series comes with an intuitive graphical user interface (GUI) and free PC-based

application software that make it easy for you to begin making productive measurements immediately. These features make the B2900A Series the best solution for accurate characterization of varistors and other devices. Figure 1 illustrates the connections necessary for measuring a varistor using the B2900A Series. The B2900A Series allows you to accurately and easily measure the basic IV parameters and characteristics of varistors, including tests such as varistor voltage and leakage current.

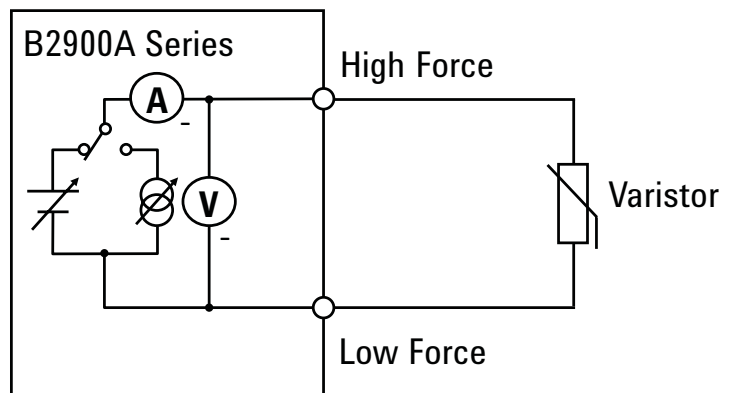

Figure 1. Image of B2900A Series and its circuit diagram to characterize a varistor.

What is the B2900A Series SMU?

An SMU combines the capabilities of a current source, a voltage source, a current meter and a voltage meter along with the capability to switch easily between these various functions into a single instrument. This gives it the ability to evaluate the IV characteristics of devices across all four measurement quadrants without the need for any additional equipment. Besides being able to output and measure voltage or current very accurately, SMUs also possess a compliance feature that allows a limit to be placed on the voltage or current output to prevent device damage. The B2900A Series members are single or dual channel SMU units that offer a wide range of IV measurement capability for a variety of two-terminal and three-terminal devices. They cover currents from 10 fA to 10.5 A and voltages from 100 nV to 210 V. In addition to their DC operation mode, the B2900A Series units also have the ability to perform pulsed measurements in order to prevent device self-heating from distorting the measurement results.

The B2900A Series SMUs support 4-wire measurements (remote sensing) to eliminate the voltage error caused by test lead residual resistance. Measurements made through a 2-wire connection can contain significant error when the resistance

being measured is comparable to that of the test leads (please see Figure 2a). However, a 4-wire measurement uses one pair of leads to force current and the other pair of leads to monitor voltage. This eliminates cable resistance effects so that only the voltage drop across the DUT is measured (please see Figure 2b). In addition, the B2900A Series' 4-wire measurement scheme keeps the voltage between the sense points (A and B in Figure 2b) at exactly the specified voltage V_{set} thereby ensuring that your device is characterized exactly under the measurement conditions you specify.

Quick and Easy IV Characterization

During routine device evaluation it is often desirable to make a quick measurement from the instrument's front panel without having to go through

the time and trouble of writing a test program. To meet this need, all members of the B2900A Series have a resident GUI that makes it easy to perform a variety of tests and save measurement data without having to write any code.

The B2900A Series' wide QVGA LCD display supports an easy-to-use GUI that provides easy instrument control from the front panel (please see Figure 3).

The B2900A Series' GUI has the following multiple viewing modes: Single View, Dual View, Graph View and Roll View (for viewing time domain measurements). Single View mode allows you to easily set up not only constant voltage and current measurements but also swept voltage and current measurements. Dual View can perform similar functions

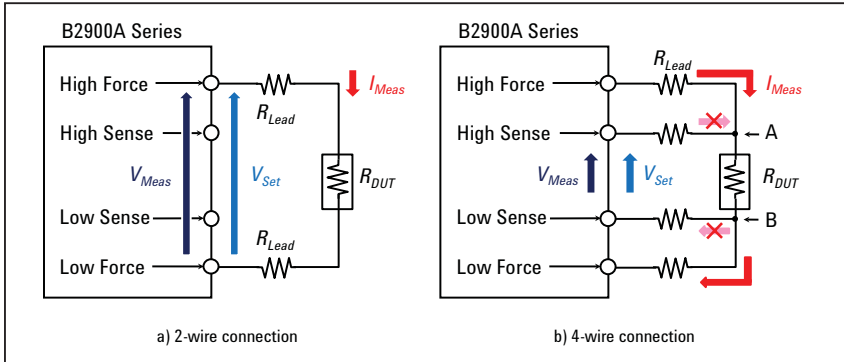

Figure 2. A 4-wire connection eliminates the measurement error caused by residual lead resistance

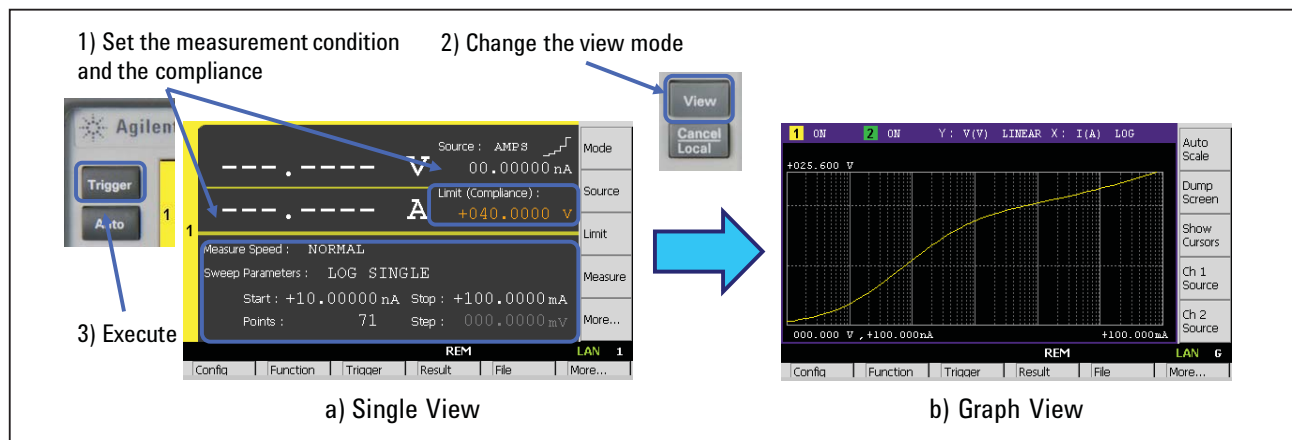

Figure 3. The B2900A Series' GUI makes it easy to take a quick measurement and display the results

for both channels simultaneously (for B2902A and B2912A). After measurement completion you can use the front panel GUI to graphically view measurement results such as IV curves using Graph View, and display a list of the measurement data using the Measure Result dialog window.

The B2900A Series has a USB interface on the front panel so that a USB flash memory device can be used with the B2900A Series to save and load measurement setups as well as to save measurement results. In addition, Graph View supports a Screen Dump function that enables you to save screen images (such as IV curves) to any attached USB flash memory device as JPEG files, making it easy to include graphical results in reports and presentations (please see Figure 4).

Ready-to-use PC software

In addition to its powerful and easy-to-use GUI, the B2900A Series comes with free PC application software to facilitate program development if you prefer PC-based instrument control. The Agilent B2900A Graphical Web Interface and the Agilent B2900A Quick I/V Measurement Software are both available for the B2900A Series.

The Agilent B2900A Graphical Web Interface provides functionality to allow access to the B2900A Series over a LAN connection. The B2900A Series is fully compliant with the LXI class C specification and it contains a web server that provides a webpage with an interface to support the B2900A Series' basic measurement functions. You can quickly and easily make measurements using a standard web browser by just connecting the B2900A Series to a PC using a LAN cable.

The Agilent B2900A Quick I/V Measurement Software has more powerful measurement capabilities to

control the B2900A Series over GPIB, USB or LAN connections (please see Figure 5). You can download this PC-based software from Agilent's web site for free. The Agilent B2900A Quick I/V Measurement Software also supports a variety of functions such as a sweep measurement, a sampling measurement, graphical display functions and the ability to save test results into CSV files

Easy custom program support

If you have specialized programming needs then both Standard Commands for Programmable Instruments (SCPI)

and IVI-COM drivers are available for the B2900A Series. SCPI is an industry-standard command set for basic instruments, and it has a uniform structure that supports a common set of commands. The B2900A Series' SCPI command set not only supports its advanced features but also general-purpose SMU commands (such as those used by the Keithley 2400) to simplify test program migration. In addition to SCPI, the B2900A Series IVI-COM drivers work in a variety of programming environments and languages so that you can develop programs without having to use low-level commands.

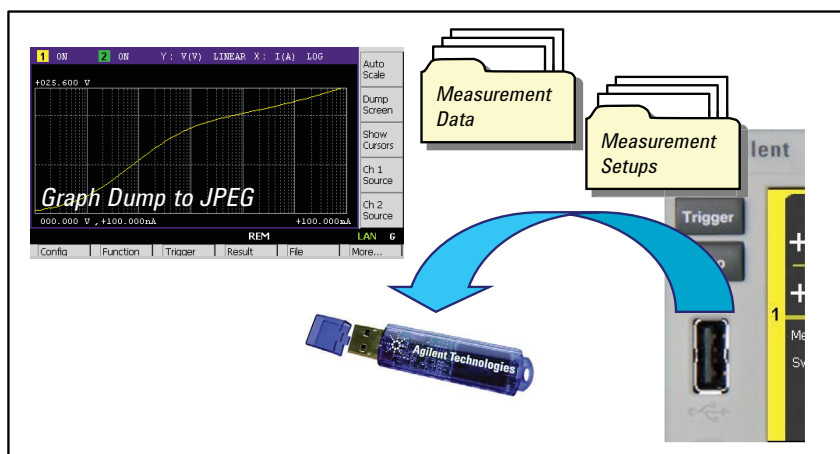

Figure 4. Measurement results and measurement setups can be saved to any attached USB flash memory device

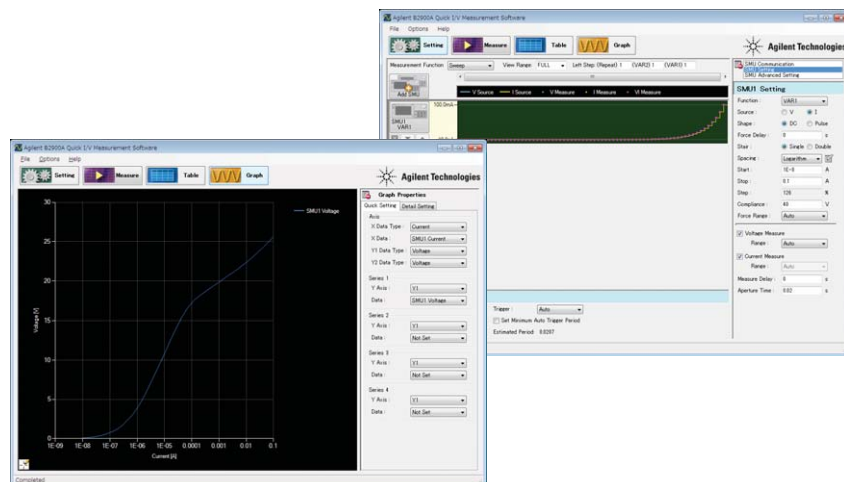

Figure 5. . It is easy to make a quick measurement on a PC using the Agilent B2900A Quick I/V Measurement Software

Summary

The Agilent B2900A Series of Precision Source/Measure Units is the best solution for IV characterization of varistors and a variety of other devices. Its wide current and voltage measurement ranges (from 10 fA/100 nV to 10.5 A/210 V) provide superior measurement performance and allow you to characterize devices more accurately and easily than ever before.

The B2900A Series' easy-to-use GUI has a variety of capabilities and features that make it easy to take measurements quickly and to save both the measurement setup conditions and data to USB-based flash memory devices.

In addition to being able to control the B2900A Series remotely over GPIB, USB and LAN interfaces, Agilent supplies PC-based Agilent B2900A Graphical Web Interface and Agilent B2900A Quick I/V Measurement Software for free to simplify controlling the B2900A Series from your PC.

For more detailed information on the various B2900A Series models, please refer to the B2900A Series data sheet (5990-7009EN).

The B2900A Series enables you to quickly debug and accurately characterize a wide variety of devices using only a single bench-top SMU.



Agilent Advantage Services is committed to your success throughout your equipment's lifetime. We share measurement and service expertise to help you create the products that change our world. To keep you competitive, we continually invest in tools and processes that speed up calibration and repair, reduce your cost of ownership, and move us ahead of your development curve.

www.agilent.com/find/advantageservices



www.agilent.com/quality



Agilent Email Updates

www.agilent.com/find/emailupdates

Get the latest information on the products and applications you select.



www.lxistandard.org

LAN eXtensions for Instruments puts the power of Ethernet and the Web inside your test systems. Agilent is a founding member of the LXI consortium.

Agilent Channel Partners

www.agilent.com/find/channelpartners

Get the best of both worlds: Agilent's measurement expertise and product breadth, combined with channel partner convenience.

Microsoft and Windows® are U.S registered trademarks of the Microsoft Corporation.

www.agilent.com

www.agilent.com/find/b2900a

For more information on Agilent Technologies' products, applications or services, please contact your local Agilent office. The complete list is available at:

www.agilent.com/find/contactus

Americas

Canada	(877) 894 4414
Brazil	(11) 4197 3500
Latin America	305 269 7500
Mexico	01800 5064 800
United States	(800) 829 4444

Asia Pacific

Australia	1 800 629 485
China	800 810 0189
Hong Kong	800 938 693
India	1 800 112 929
Japan	0120 (421) 345
Korea	080 769 0800
Malaysia	1 800 888 848
Singapore	1 800 375 8100
Taiwan	0800 047 866
Thailand	1 800 226 008

Europe & Middle East

Austria	43 (0) 1 360 277 1571
Belgium	32 (0) 2 404 93 40
Denmark	45 70 13 15 15
Finland	358 (0) 10 855 2100
France	0825 010 700*

*0.125 €/minute

Germany	49 (0) 7031 464 6333
Ireland	1890 924 204
Israel	972-3-9288-504/544
Italy	39 02 92 60 8484
Netherlands	31 (0) 20 547 2111
Spain	34 (91) 631 3300
Sweden	0200-88 22 55
Switzerland	0800 80 53 53
United Kingdom	44 (0) 118 9276201

Other European Countries:

www.agilent.com/find/contactus

Revised: July 8, 2010

Product specifications and descriptions in this document subject to change without notice.

© Agilent Technologies, Inc. 2011
Printed in USA, February 8, 2011
5990-7116EN



Agilent Technologies